



THROUGH HOLE TAB- UP RJ-45 JACK WITH 10/100/1000 MAGNETIC

FEATURES

- 1X1 Tab-UP, 0.85" & 1" long with internal magnetics for 10/100/1000 Base-TX
- 350 μ H minimum OCL with 8mA bias current
- Internal magnetics options available
- Minimum 1500Vrms isolation
- Recognized by UL 60950-1



ELECTRICAL SPECIFICATIONS @25°C-Operating temperature 0°C TO 70°C

Part Number	Turns Ratio		Insertion Loss (dB MAX)	Return Loss (dB MIN @100 Ω ±15 Ω)				Differential to Common Mode Rejection (dB MIN)			Cross talk (dB MIN)			Hipot (VRMS)
	TX	RX		0.3-100MHz	1-30 MHz	40 MHz	50 MHz	60-100 MHz	30 MHz	60 MHz	100 MHz	30 MHz	60 MHz	
46F-1301GDD2	1CT:1CT	1CT:1CT	-1.2	-16	-13.5	-11.5	-10	-35	-32	-30	-40	-36	-30	1500
46F-1302GYD2	1CT:1CT	1CT:1CT	-1.2	-16	-13.5	-11.5	-10	-35	-32	-30	-40	-36	-30	1500
46F-1301GYD2	1CT:1CT	1CT:1CT	-1.2	-16	-13.5	-11.5	-10	-35	-32	-30	-40	-36	-30	1500
46F-1303GYD2	1CT:1CT	1CT:1CT	-1.2	-16	-13.5	-11.5	-10	-35	-32	-30	-40	-36	-30	1500
47F-1302GYD2	1CT:1CT	1CT:1CT	-1.1	-15	-15	-15	-12	-35	-32	-30	-35	-26	-24	1500
46F-1201YGD2	1CT:1	1CT:1CT	-1.2	-14	-14	-14	-10	-35	-32	-30	-40	-36	-30	1500
46F-1202YGD2	1CT:1CT	1CT:1CT	-1.2	-14	-14	-14	-10	-35	-32	-30	-40	-36	-30	1500
46F-1203GGD2	1CT:1CT	1CT:1CT	-1.2	-14	-14	-14	-10	-35	-32	-30	-40	-36	-30	1500
Part Number	Turns Ratio		Insertion Loss (dB MAX)	Return Loss (dB MIN @100 Ω ±15 Ω)				Common Mode Rejection (dB MIN)			Cross talk (dB TYP)	Hipot (VRMS)		
	TX	RX		0.1-100MHz	1-30 MHz	40 MHz	50 MHz	60-80 MHz	32 MHz	62 MHz			100 MHz	
46F-1403GYD2	1CT:1CT	1CT:1CT	-1.2	-16	-14	-13	-12	-42	-37	-33	-33	1000		

Part Number:

46F - 1301 GDD NW 2 NL A:Series
 A B C D E F B:Schematics
 C:Led
 D:Mechanical
 E:Gold Plating:1=3u",2=6u",3=15u",4=30u",5=50u"
 F:RoHS Version

MARKINGS AND DIMENSION

46F-12XX

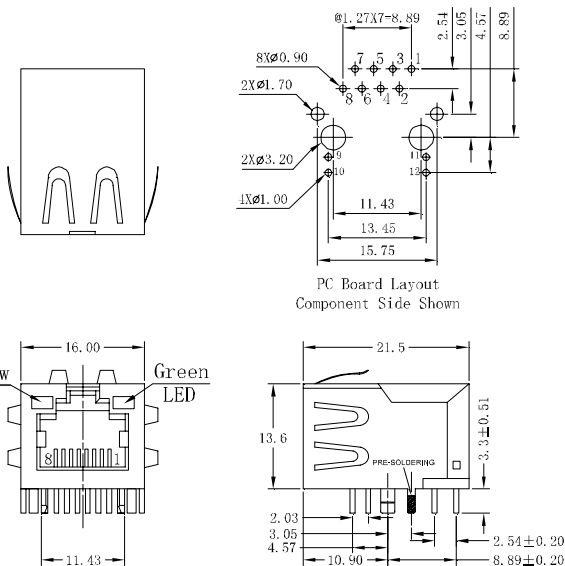

LED Configuration:

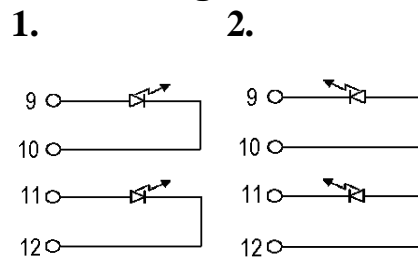

Standard LED	Wavelength	Forward* V(MAX)	(TYP)
Yellow	585 nm	2.5 V	2.1 V
Green	565 nm	2.5 V	2.2 V

* With a forward current of 20 mA

UNIT:mm Unless otherwise specified, all tolerances are ±0.25



THROUGH HOLE TAB- UP RJ-45 JACK WITH 10/100/1000 MAGNETIC

MARKINGS AND DIMENSION

46F-13XX

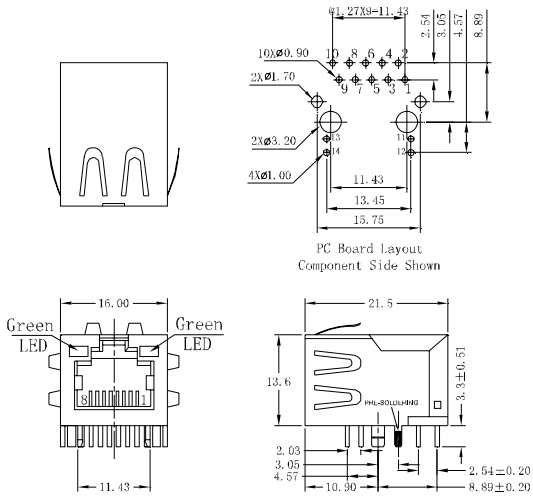

LED Configuration:

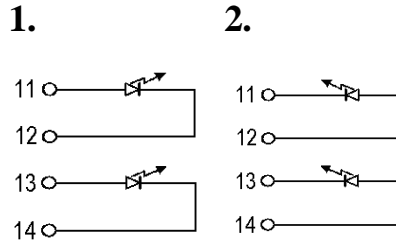

Standard LED	Wavelength	Forward* V(MAX)	(TYP)
Yellow	585 nm	2.5 V	2.1 V
Green	565 nm	2.5 V	2.2 V

* With a forward current of 20 mA

UNIT:mm Unless otherwise specified, all tolerances are ±0.25

47F-13XX

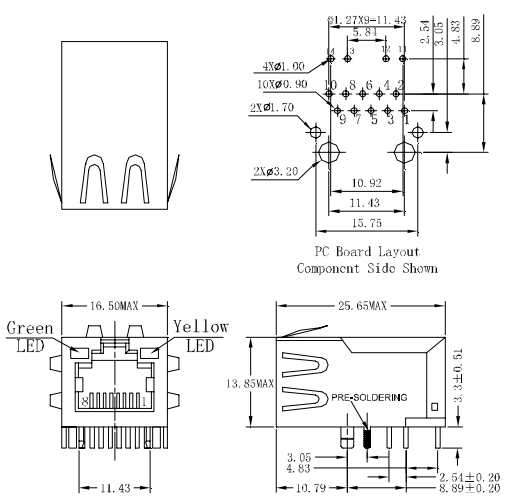

LED Configuration:

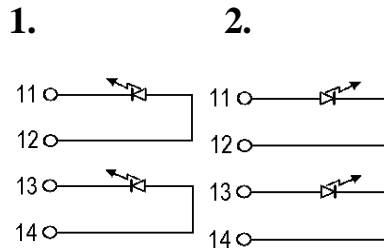

Standard LED	Wavelength	Forward* V(MAX)	(TYP)
Yellow	585 nm	2.5 V	2.1 V
Green	565 nm	2.5 V	2.2 V

* With a forward current of 20 mA

UNIT:mm Unless otherwise specified, all tolerances are ±0.25

47F-14XX

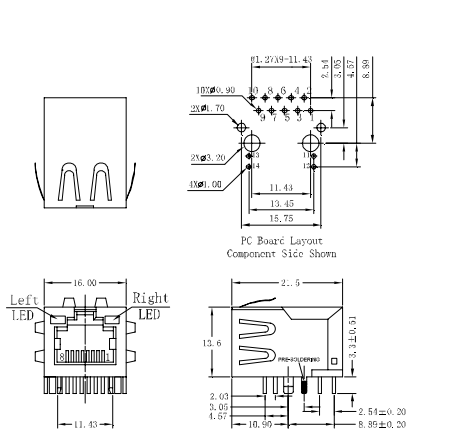

LED Configuration:

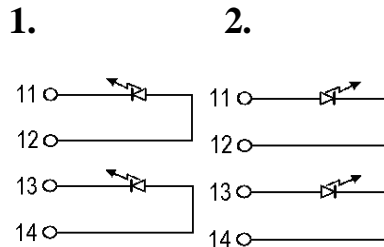

Standard LED	Wavelength	Forward* V(MAX)	(TYP)
Yellow	585 nm	2.5 V	2.1 V
Green	565 nm	2.5 V	2.2 V

* With a forward current of 20 mA

UNIT:mm Unless otherwise specified, all tolerances are ±0.25

THROUGH HOLE TAB- UP RJ-45 JACK WITH 10/100/1000 MAGNETIC

MATERIALS

1.Housing Material:

MATERIAL:NYLON GF (Fr50) UL94V-0
STANDARD COLOR:BLACK

2.Insert Material:

MATERIAL:Phos-Bronze C5210 EH--0.35mm Thickness
Insert -PBT GF UL94V-0
1.PLATING(1) NICKEL
2.PLATING(2) 100% Sn
3.PLATING(3) GOLD (3u" ~50u")

3.Plate Material: PBT GF UL 94V-0

4.Contact pin Material:

MATERIAL: Phos-Bronze C5191---0.35mm Thickness
1.PLATING(1) NICKEL
2.PLATING(2) 100% Sn

5.Shielding Material:

BRASS C2680 PLATING NICKEL

6.Operation Life : 750 Cycles Min.

7.Environmental

- 1.Storage Temp:-40°C TO +85°C
- 2.Operating Temp: 0°C TO +70°C.
- 3.MATES WITH MODULAR PLUG CONFORMING TO FCC PART 68,SUBPARTF.

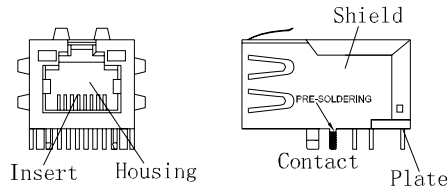

SCHEMATICS

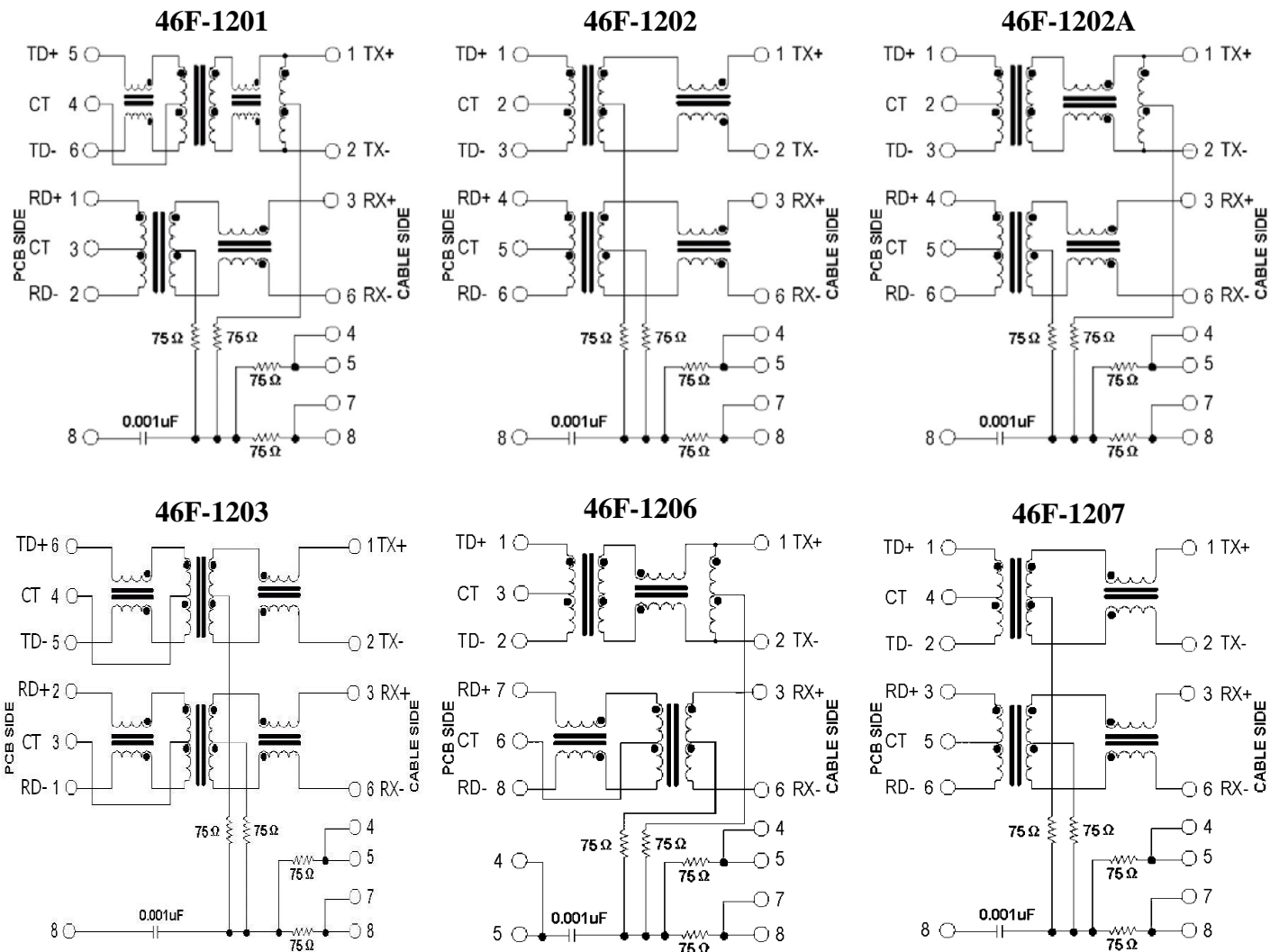



46F-1208

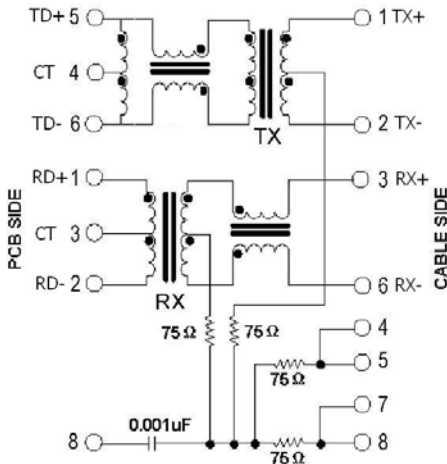

46F-1209

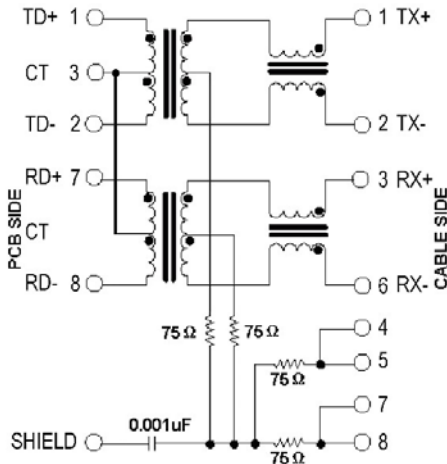

46F-1210

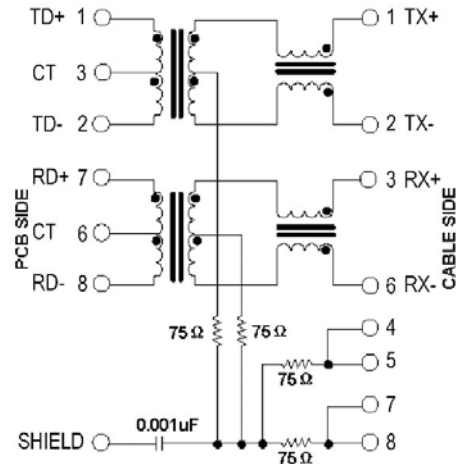

46F-1210A

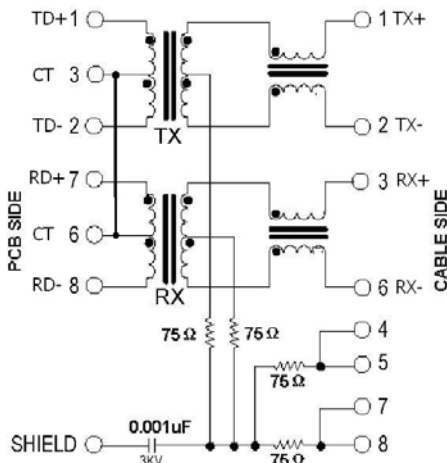

46F-1211

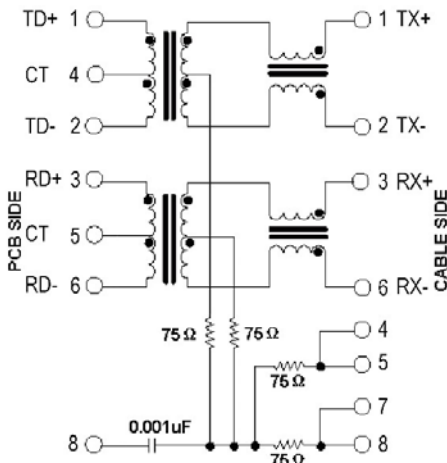

46F-1215

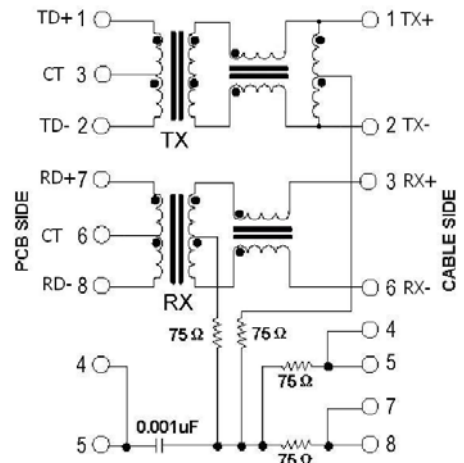

46F-1215B

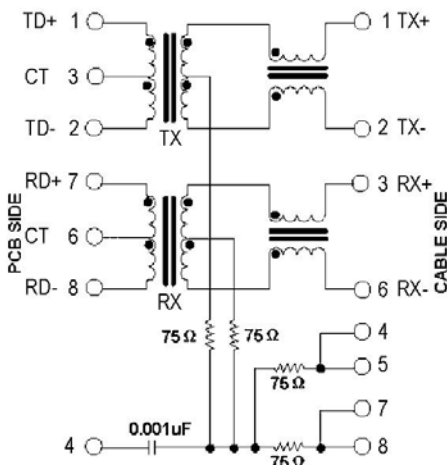

46F-1216

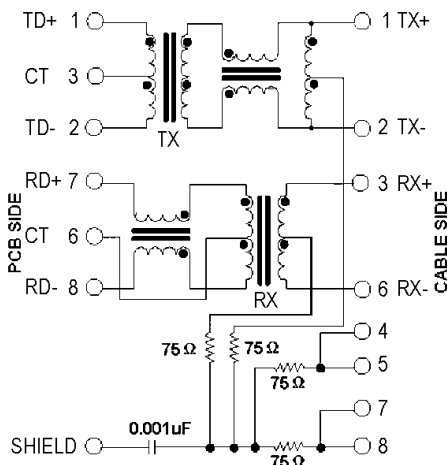

46F-1217

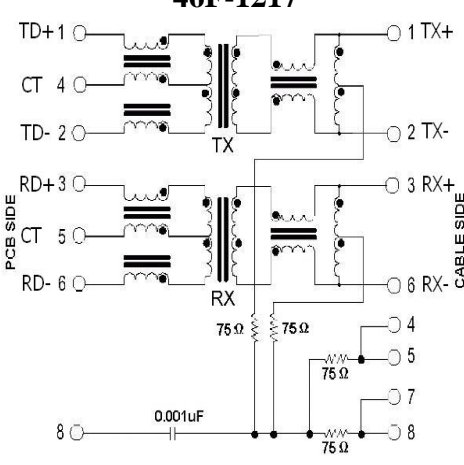

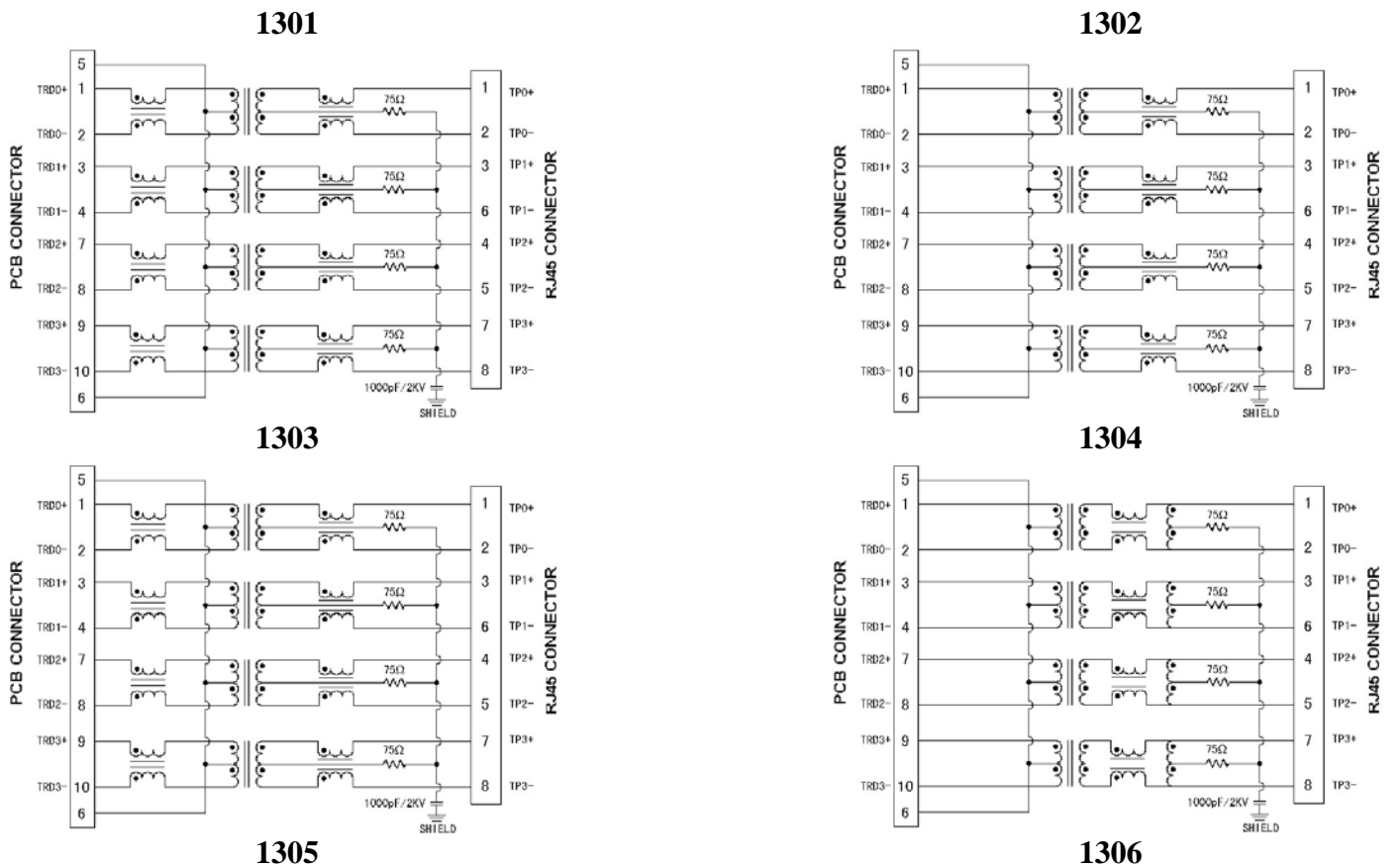
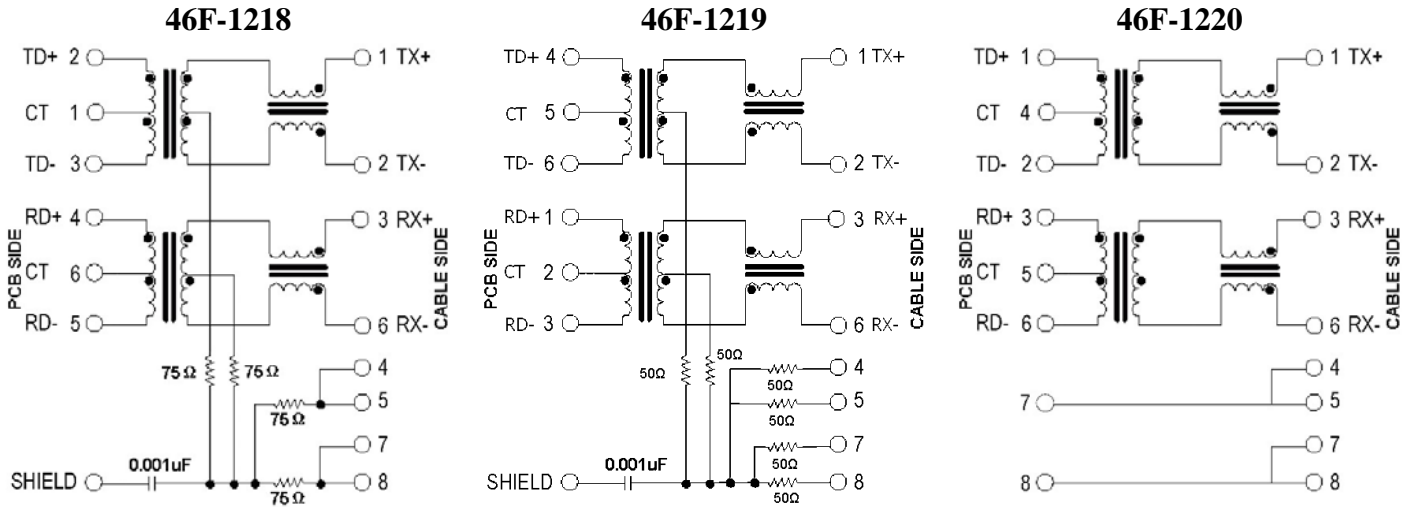



THROUGH HOLE TAB- UP RJ-45 JACK WITH 10/100/1000 MAGNETIC

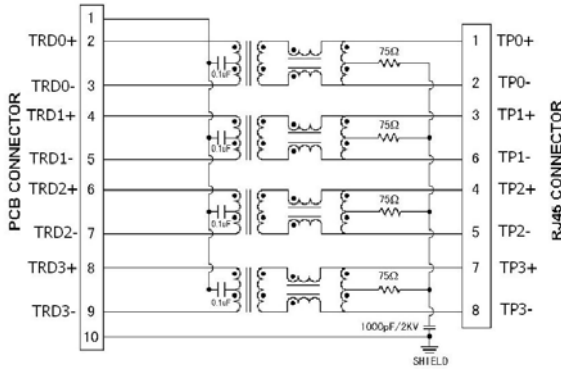

1308

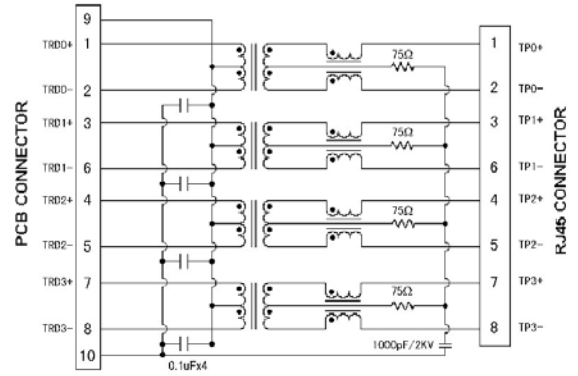

1309

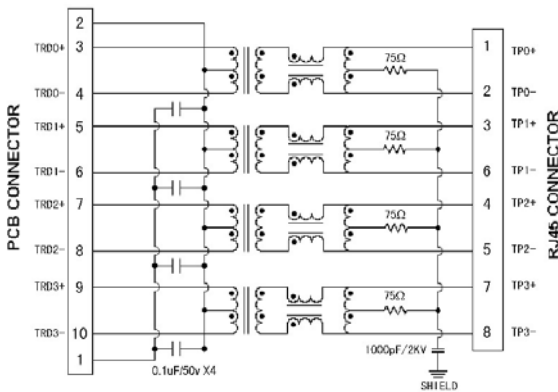

46F-1310

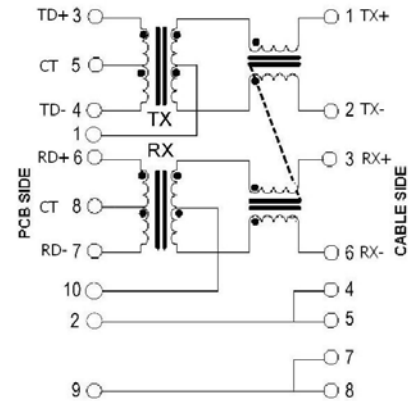

47F-1310

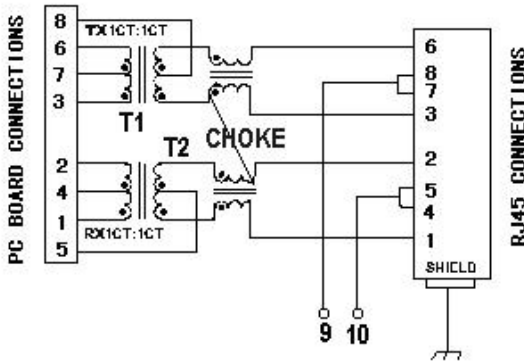

1313

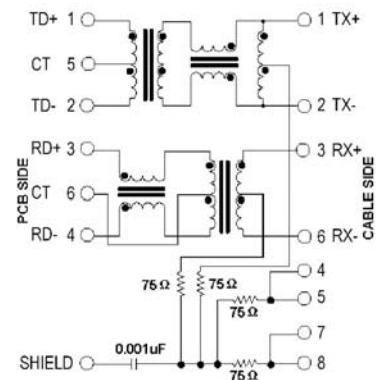

1314

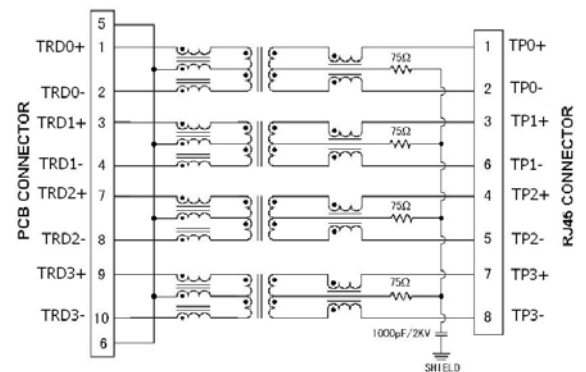
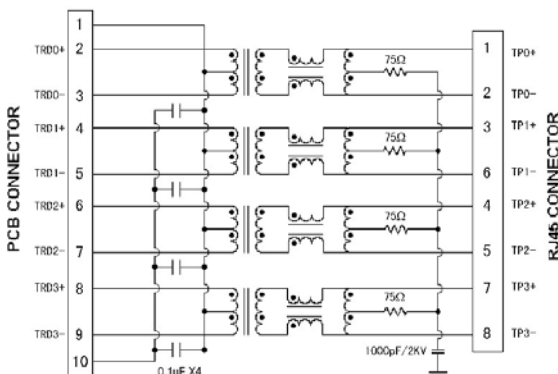



1316

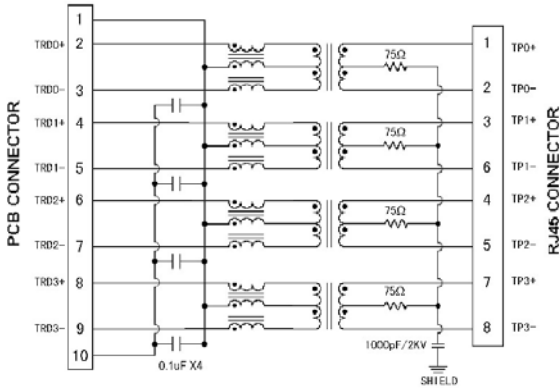

1318

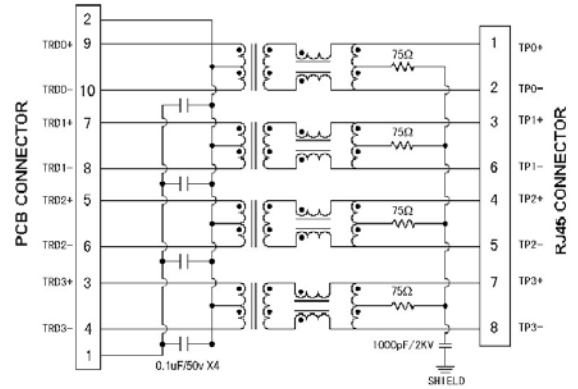

1319

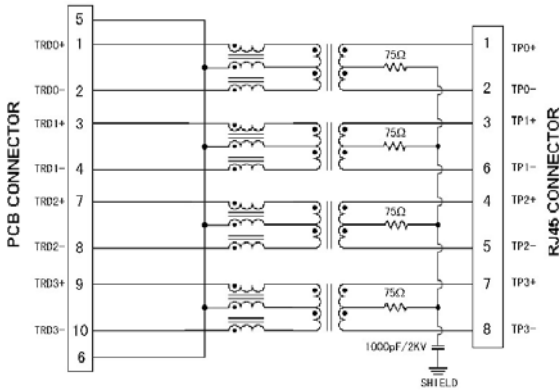

1320

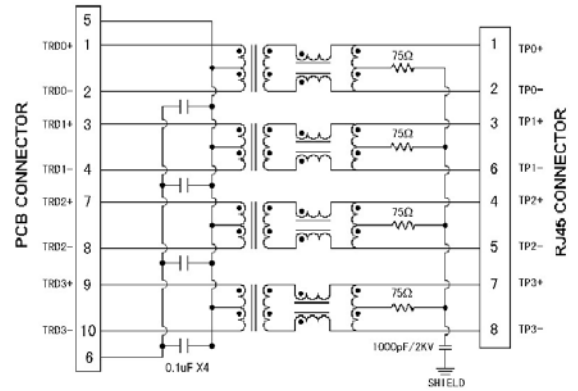

1403

